

# Packing

SOURCE:

<https://support.zortrax.com/m300-plus-packing/>

## Table Of Contents

Unloading the Material  
Packing

## Unloading the Material

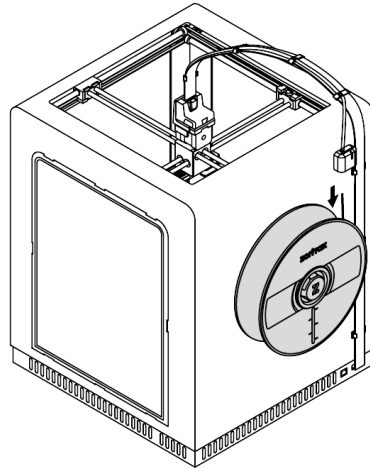

Unload the material using the options from the menu; select *Tools, Material* and *Unload material*. Then, remove the end of the material from the material endstop.

Remember to secure the end of the material using the specially designed holes in the spool.

## Packing

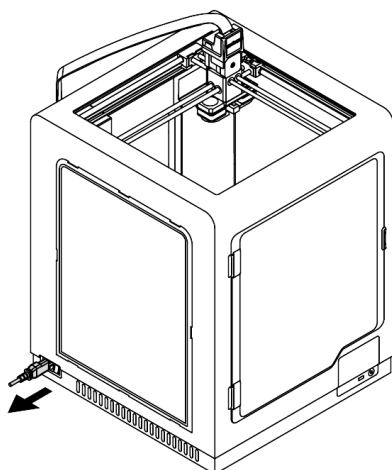

Turn the printer off and unplug the power cable.

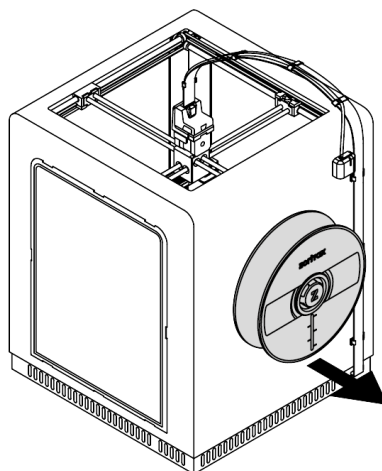

Remove the spool from the spool holder. Then, remove the spool holder.

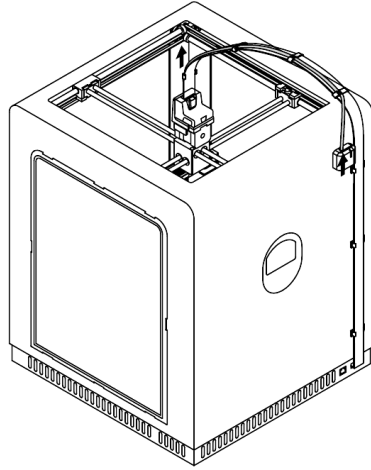

Remove the material guide from the extruder and the material endstop.

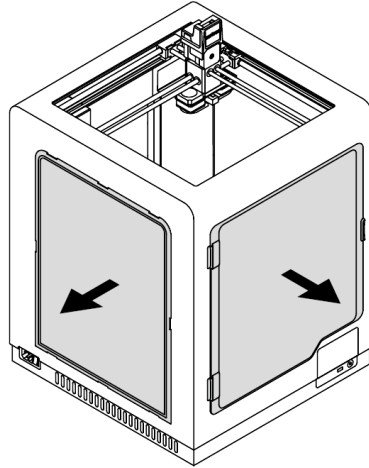

Remove the side covers.

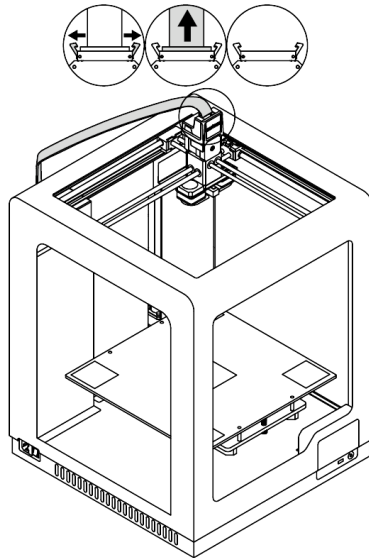

Unplug the extruder cable.

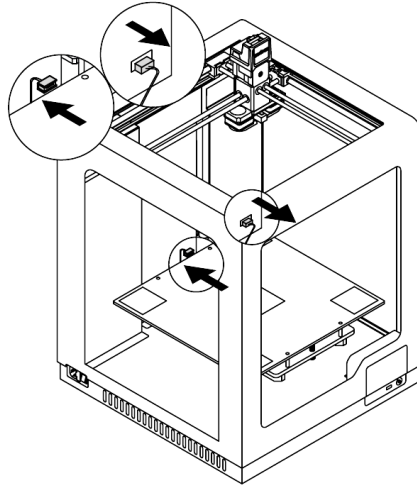

Unplug the heatbed cable from the platform and from the Z-axis cover. Remove the cable from the printer and put it in the Starter Kit box.

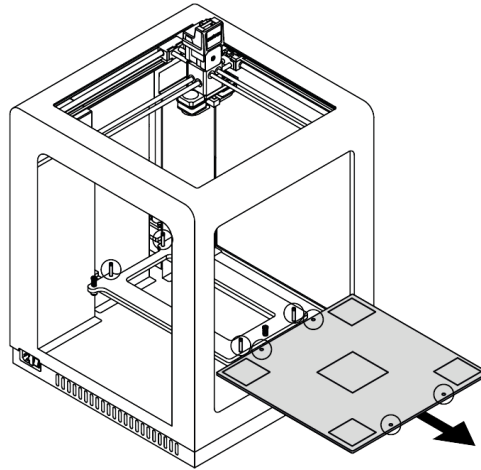

Remove the platform from the printer.

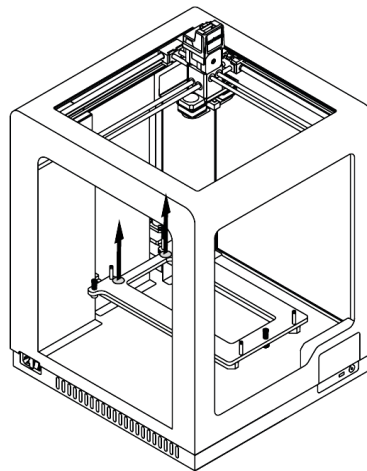

Lift the heatbed mount.



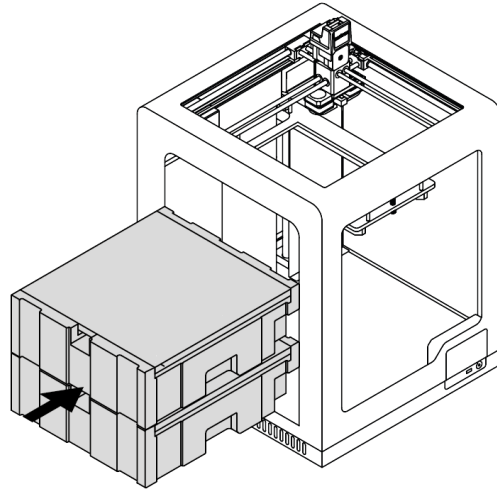

Put the platform into the accessories box and place the box on the bottom of the printer.

Put the printer's accessories in the foam and put the foam on the Starter Kit box inside the printer.

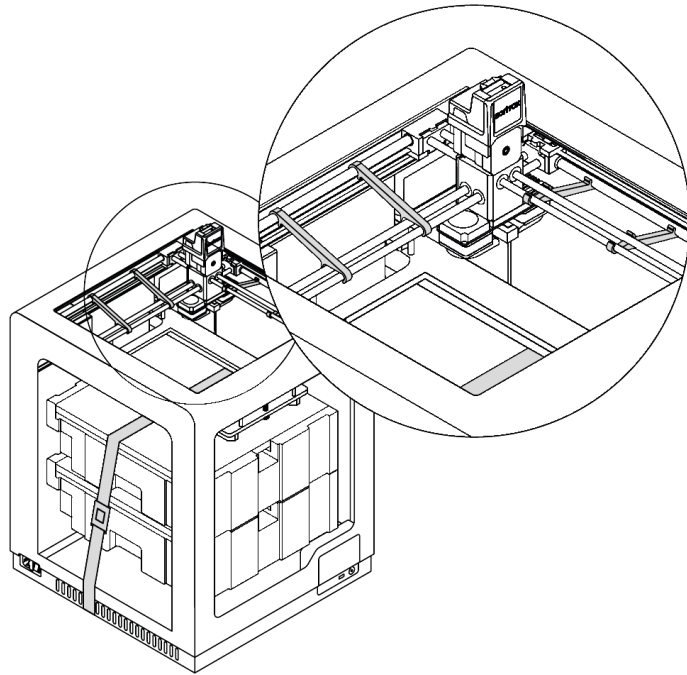

Move the extruder manually to the back right corner of the printer. Then, secure the extruder with the shipping clips.

Next, secure the foam and the Starter Kit box with the belt.

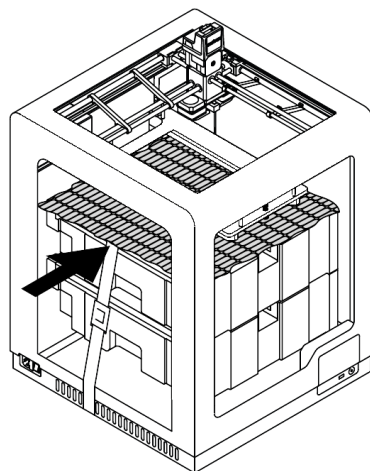

Place the fillers on the foam.

Then, lower the heatbed mount so that the box and the foam are tightly secured.

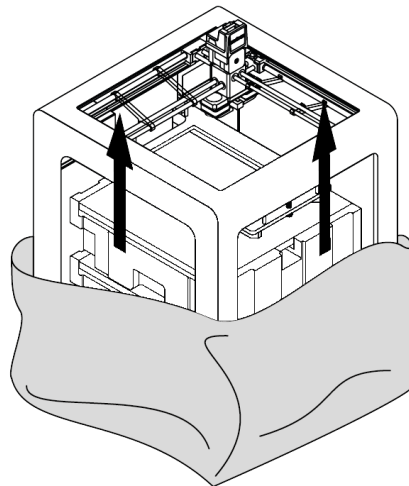

Wrap the printer in foil.

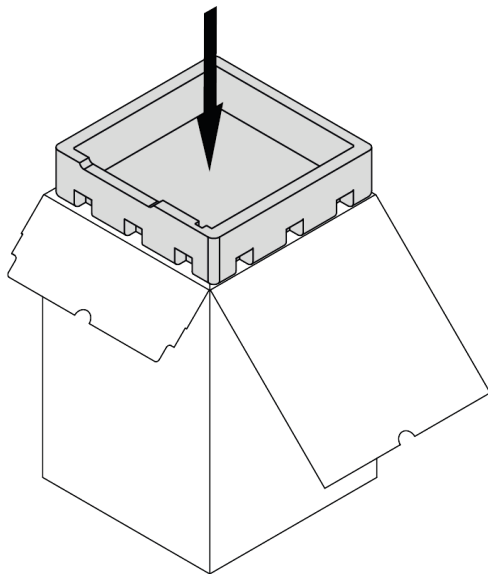

Place the cushioning at the bottom of the box.

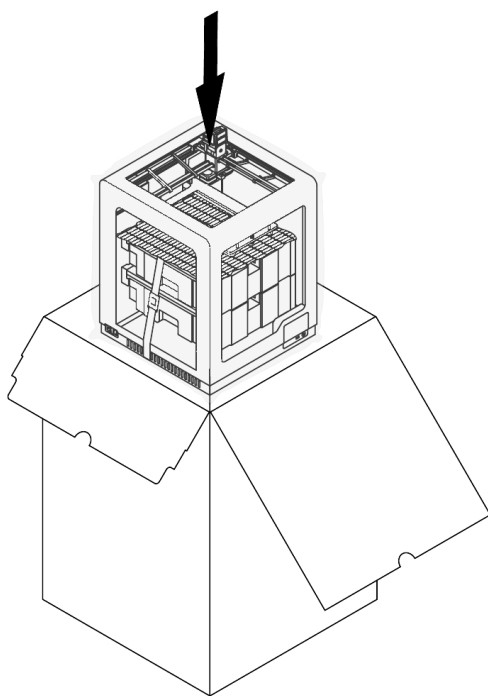

Place the printer on the bottom cushioning inside the box.

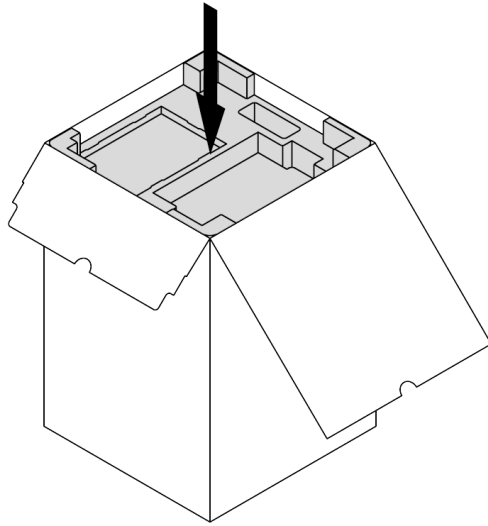

Place the top cushioning on the printer so that the cushioning fits the extruder.

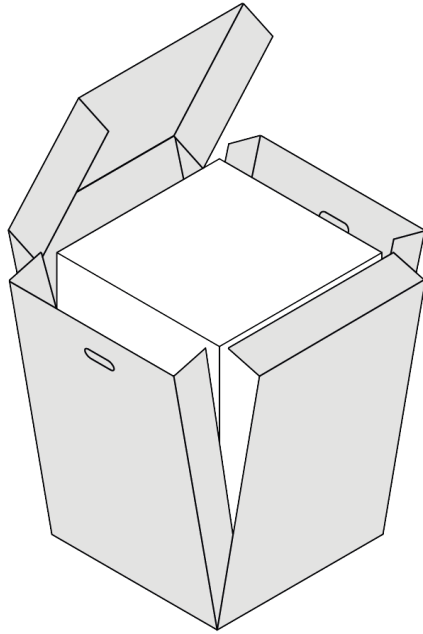

Pack the printer using the provided box.

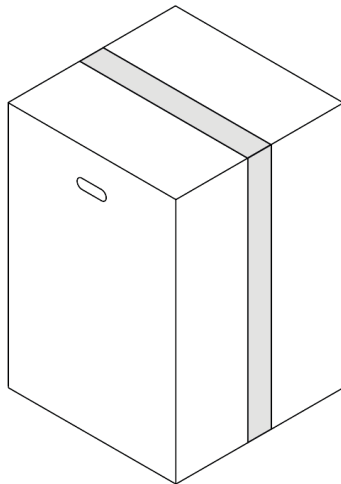

Tape the box.

