

Packing

SOURCE:

<https://support.zortrax.com/m200-plus-packing/>

Table Of Contents

Unloading the Material
Unplugging the Power Cable
Removing the Spool
Removing the Material Guide
Unplugging the Extruder Cable
Unplugging the Heatbed Cable
Removing the Platform
Removing the Side Covers
Lifting the Heatbed Mount
Placing the Starter Kit Box
Setting the Extruder in the Right Position
Placing the Fillers
Wrapping the Printer
Placing the Bottom Cushioning
Putting the Printer in the Box
Placing the Top Cushioning
Packing the Printer
Taping the Box

Unloading the Material

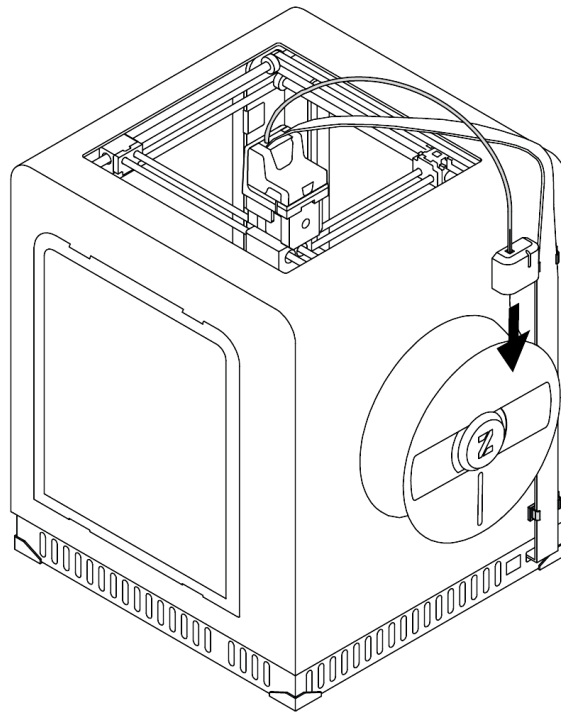

Unload the material using the options from the menu; select *Tools, Material* and *Unload material*. Then, remove the end of the material from the material endstop.

Remember to secure the end of the material using the specially designed holes in the spool.

Unplugging the Power Cable

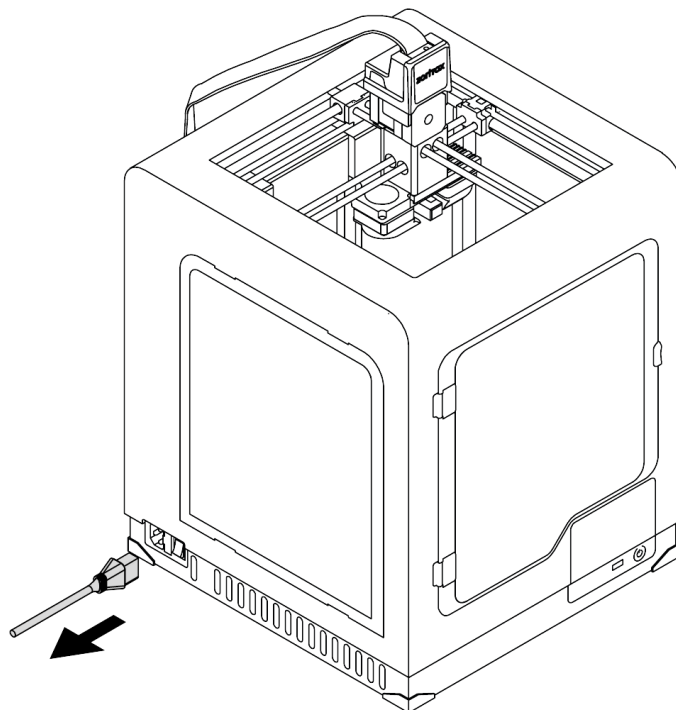

Turn the printer off and unplug the power cable.

Wait until the printer cools down.

Removing the Spool

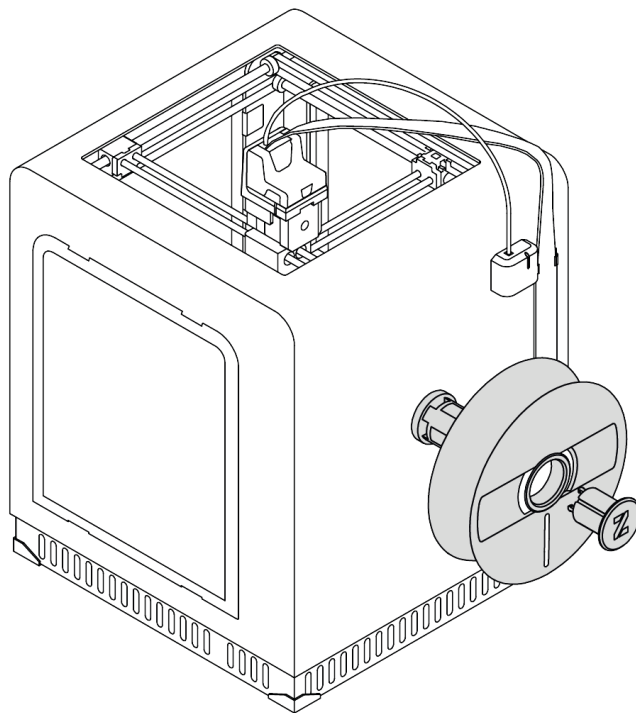

Remove the spool from the spool holder. Then, remove the spool holder.

Removing the Material Guide

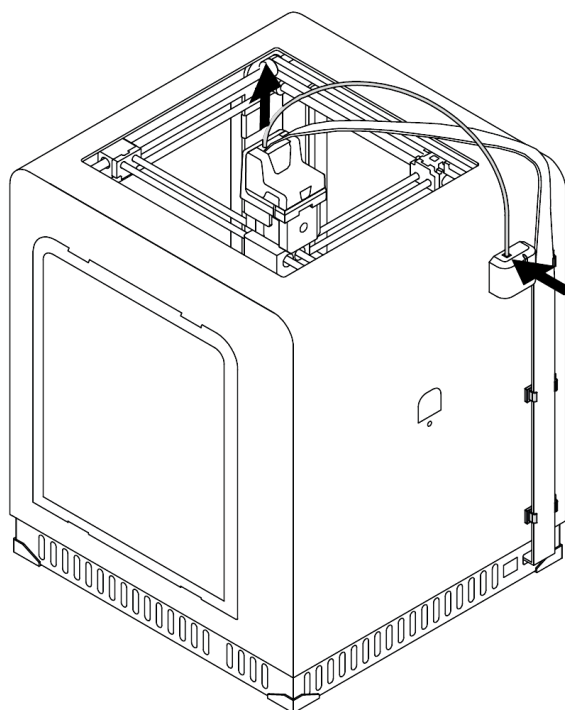

Remove the material guide from the extruder and the material endstop.

Unplugging the Extruder Cable

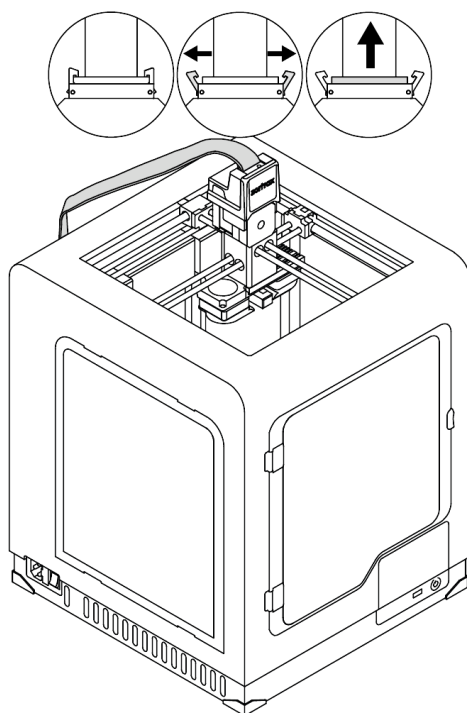

Unplug the extruder cable.

Unplugging the Heatbed Cable

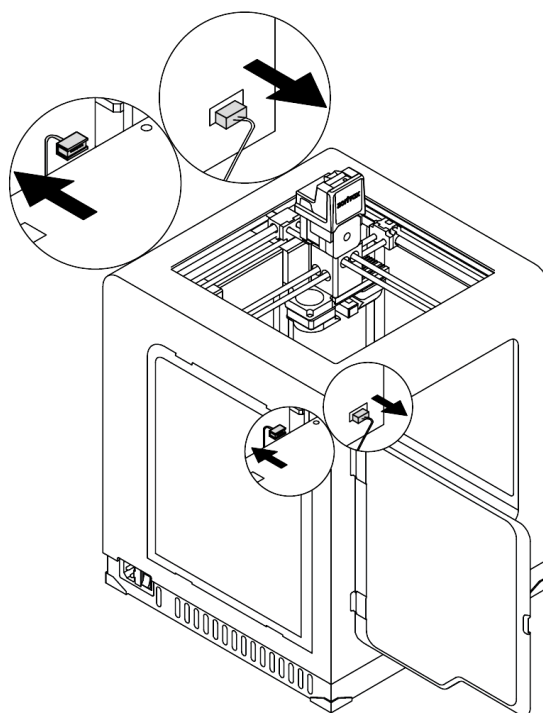

Unplug the heatbed cable from the platform and from the Z-axis cover. Remove the cable from the printer and put it in the Starter Kit box.

Removing the Platform

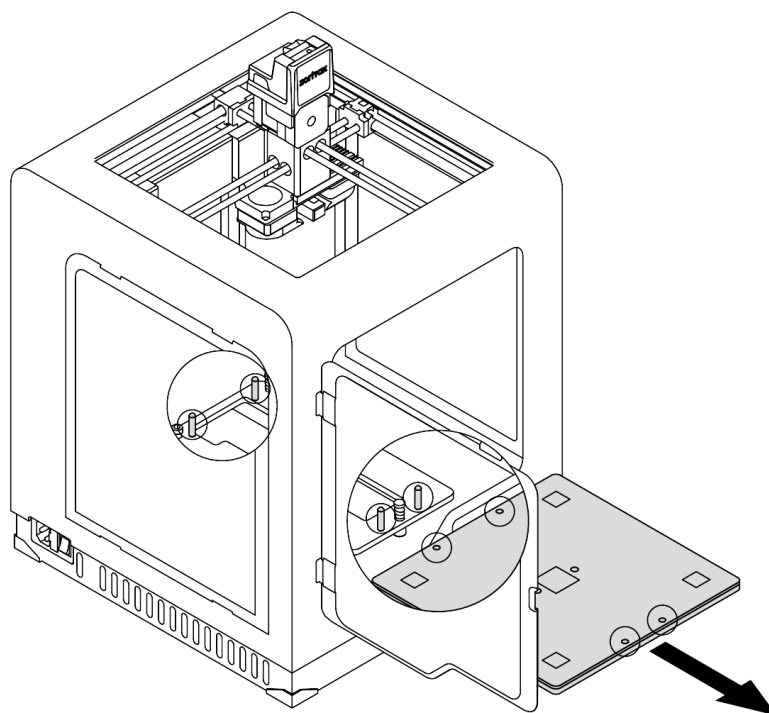

Remove the platform from the printer.

Removing the Side Covers

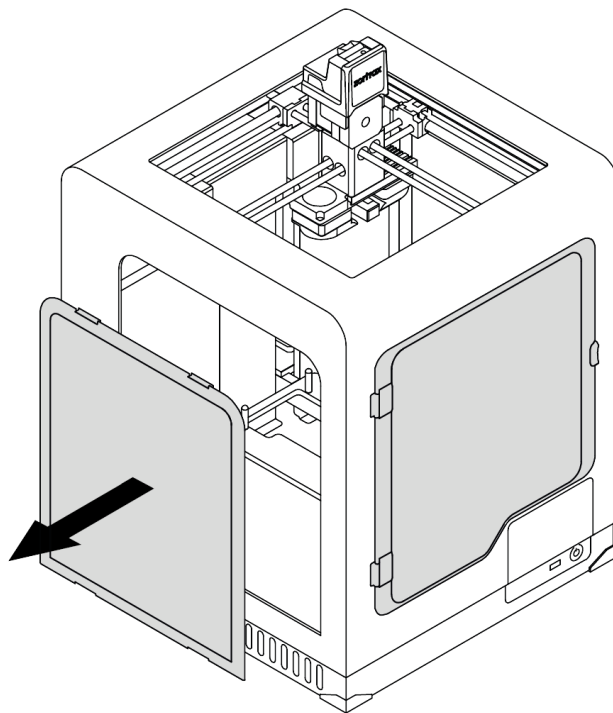

Remove the side covers.

Lifting the Heatbed Mount

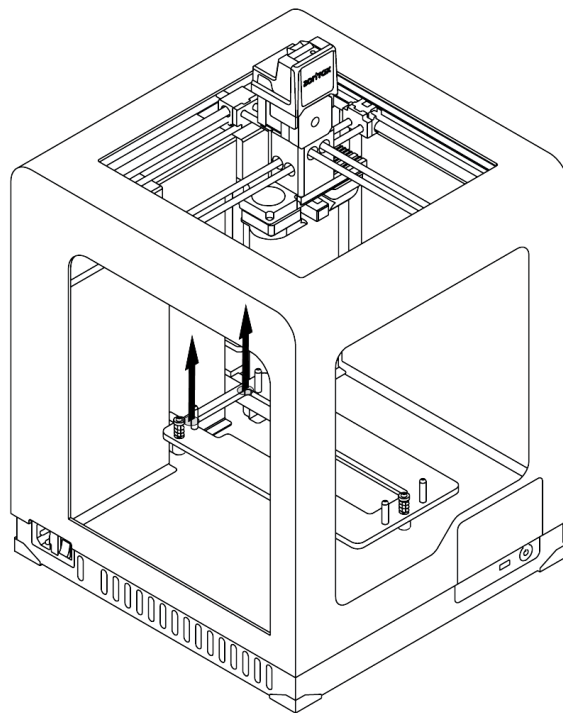

Lift the heatbed mount.

Placing the Starter Kit Box

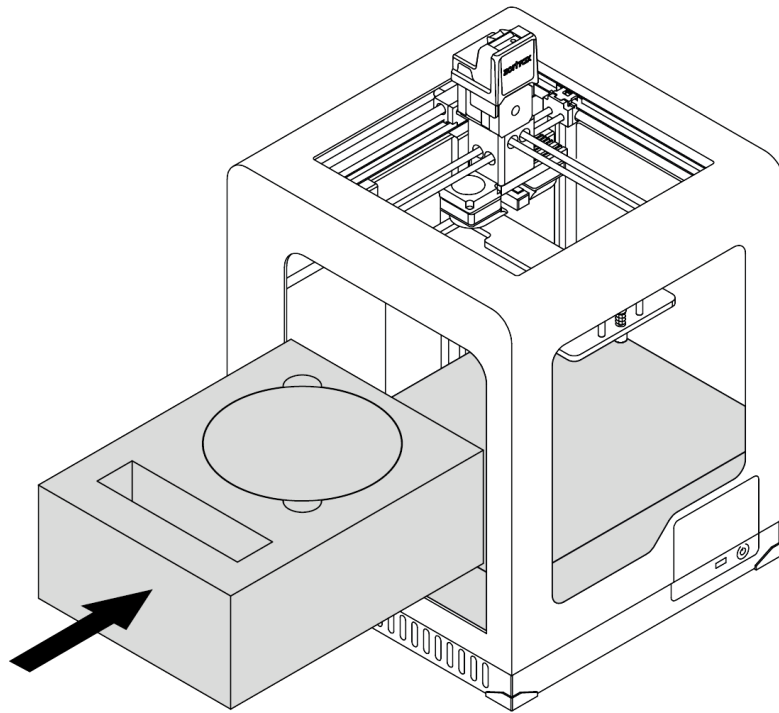

Put the platform into the Starter Kit box and place the box on the bottom of the printer.

Put the printer accessories in the accessories foam and put the foam on the Starter Kit box inside the printer. Then, lower the heatbed mount so that the box and the foam are tightly secured.

Setting the Extruder in the Right Position

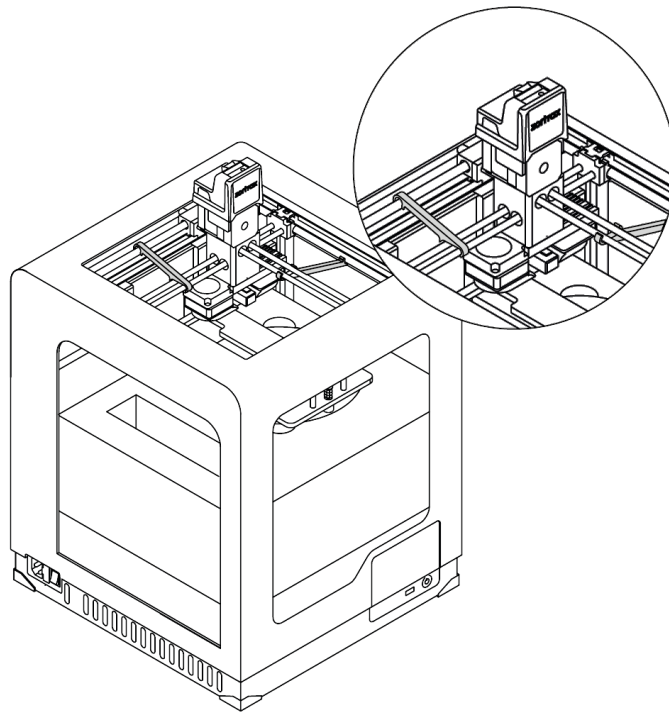

Move the extruder manually to the back right corner of the printer. Secure the extruder with the shipping clips.

Placing the Fillers

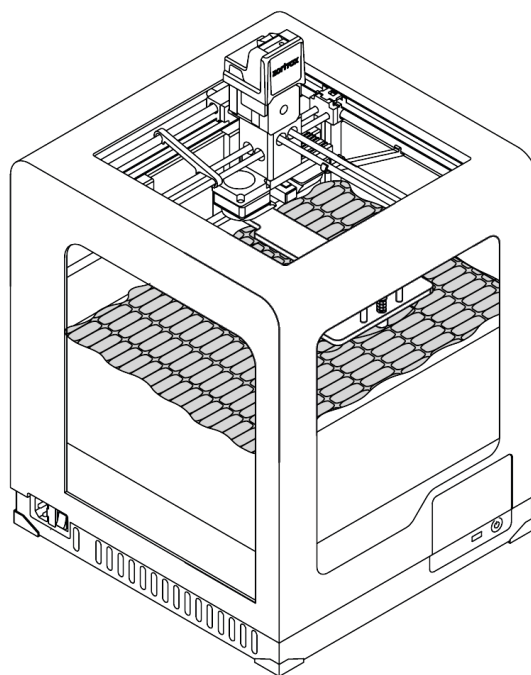

Place the fillers on the foam.

Wrapping the Printer

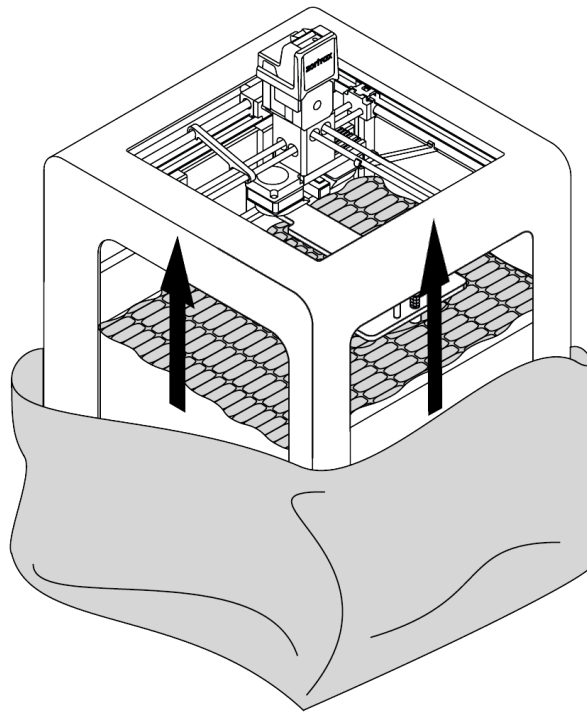

Wrap the printer in foil.

Placing the Bottom Cushioning

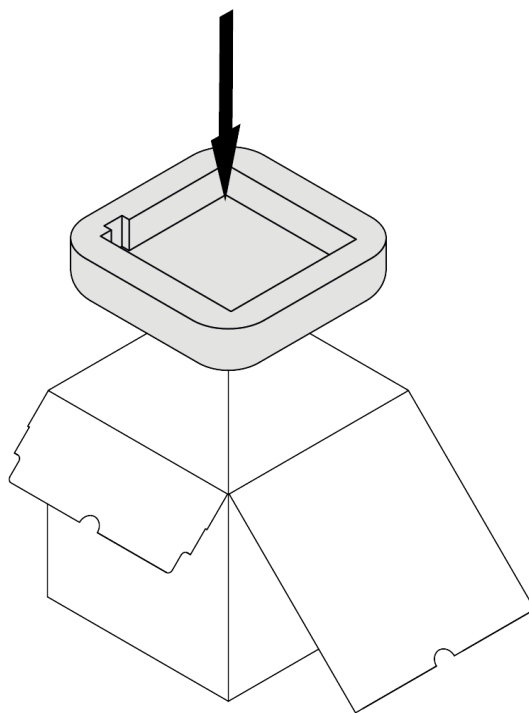

Place the cushioning at the bottom of the box.

Putting the Printer in the Box

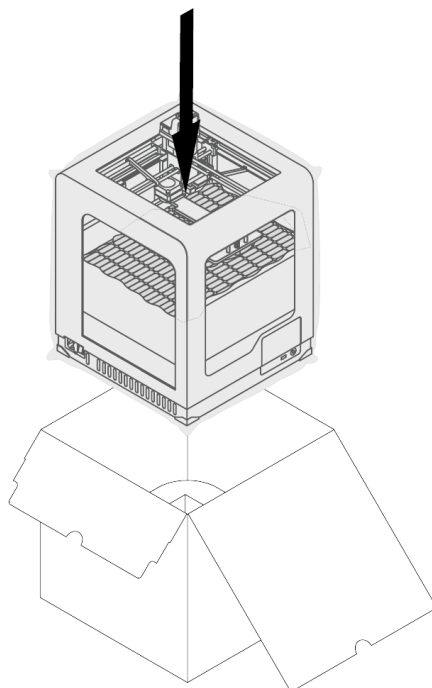

Place the printer on the bottom cushioning inside the box.

Placing the Top Cushioning

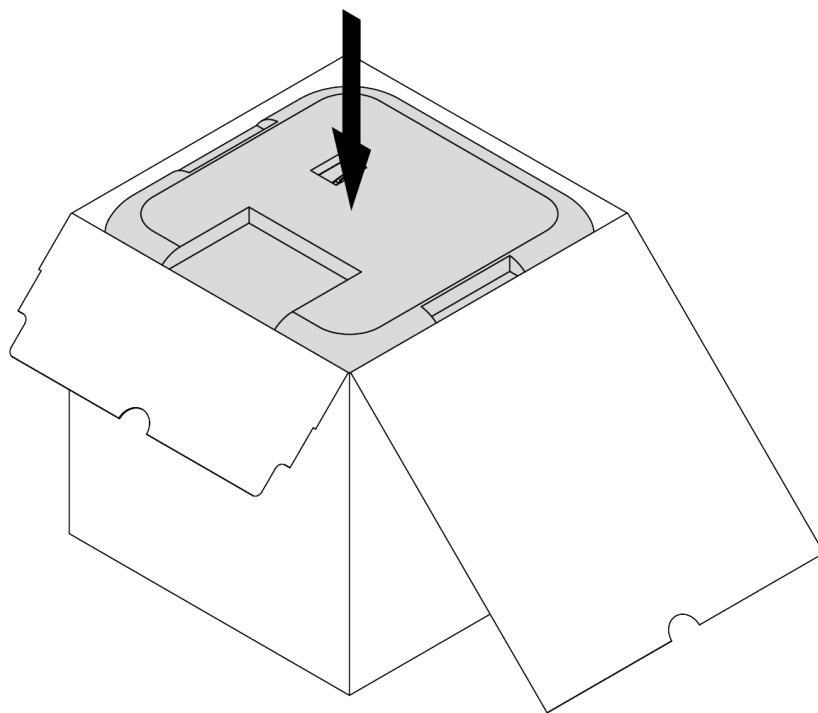

Place the top cushioning on the printer so that the cushioning fits the extruder.

Packing the Printer

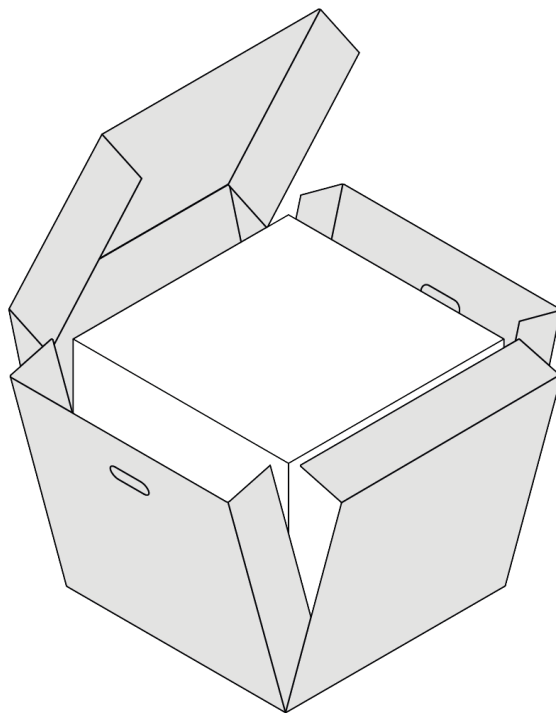

Pack the printer using the provided box.

Taping the Box

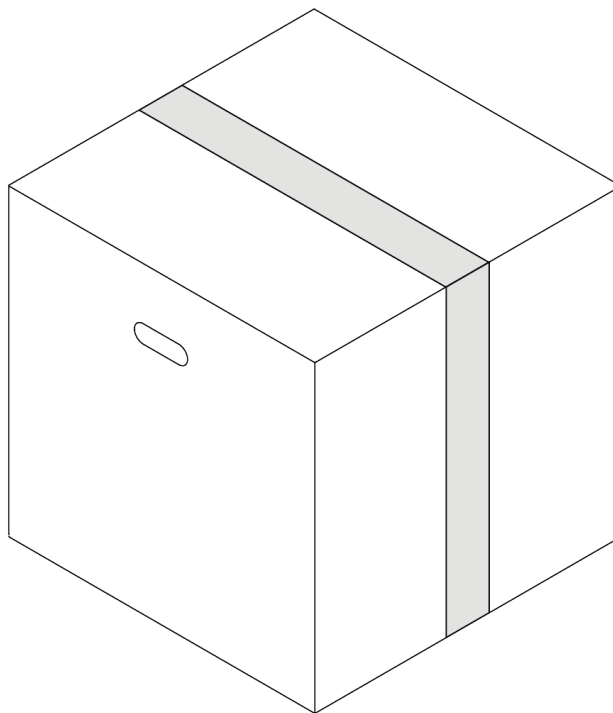

Tape the box.