

Packing

SOURCE:

<https://support.zortrax.com/m300-packing/>

Table Of Contents

Unloading the Material
Unplugging the Power Cable
Unplugging the Extruder Cable
Disassembling the Side Covers
Removing the Platform
Lifting up the Heatbed Mount
Placing the Foams with Accessories
Setting the Extruder in the Right Position
Wrapping the Printer
Placing the Bottom Cushioning
Putting the Printer into the Box
Placing the Top Cushioning
Packing the Printer
Taping the Box

Unloading the Material

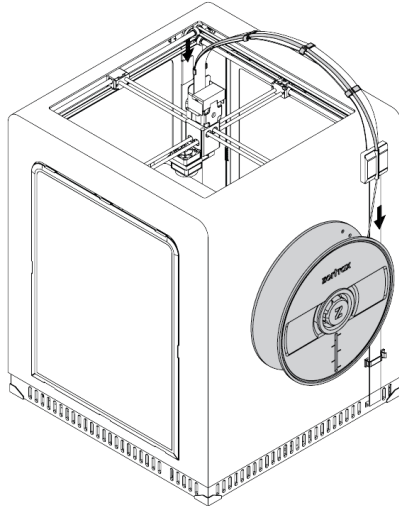

If the material is loaded into the extruder, select *Material* and then *Unload the material* from the menu. Remove the material from the material guide and remove the spool from the spool holder. Separate the spool holder from the back of the printer and remove the material guide from the clamps.

Unplugging the Power Cable

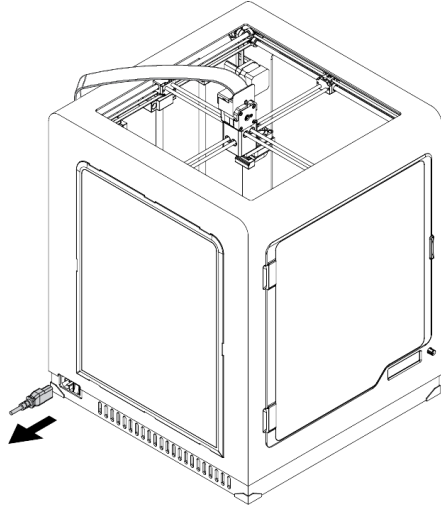

Turn the printer off, unplug the power cable and wait until the printer cools down.

Unplugging the Extruder Cable

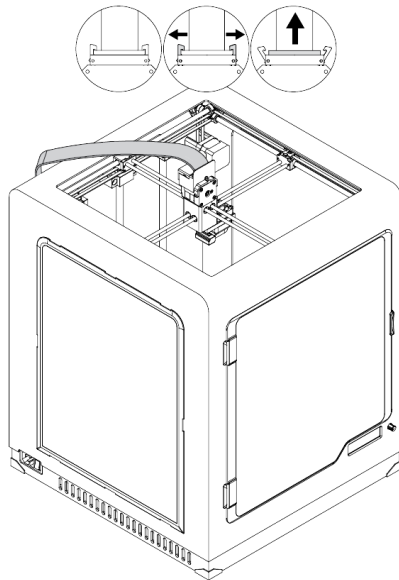

Unplug the extruder cable.

Disassembling the Side Covers

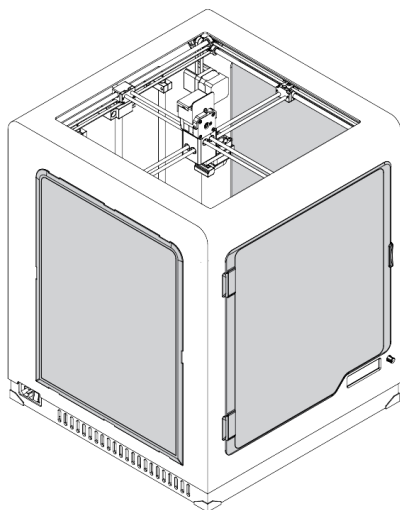

Disassemble the side covers.

Removing the Platform

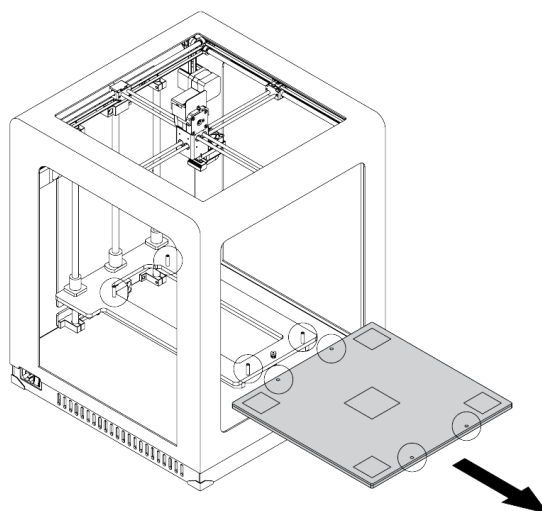

Disconnect the platform cable and remove it from the printer.

Lifting up the Heatbed Mount

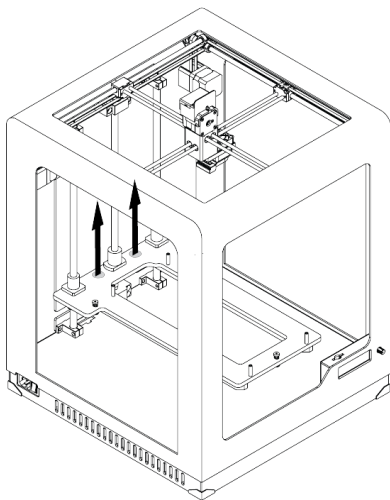

Lift up the heatbed mount.

Placing the Foams with Accessories

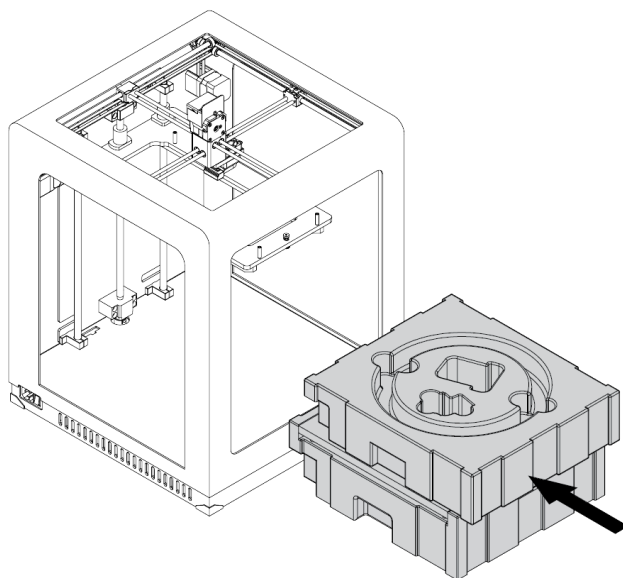

Put the platform in the foam with accessories and place the foam on the bottom of the printer.

Setting the Extruder in the Right Position

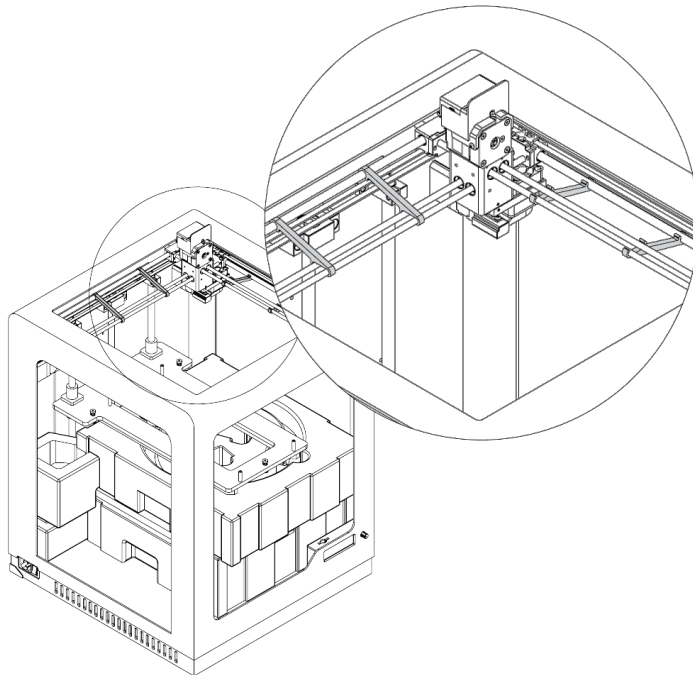

Move the extruder manually to the end of X axis and then to the end of Y axis so the extruder is placed at the top right corner of the printer. Put the shipping clips on both axes.

Wrapping the Printer

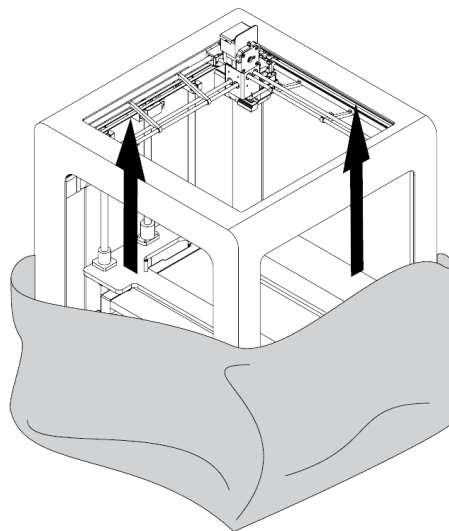

Wrap the printer in foil.

Placing the Bottom Cushioning

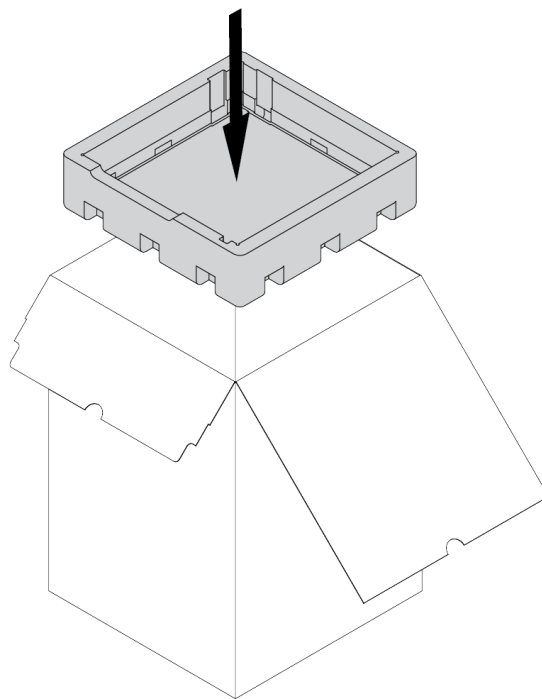

Place the cushioning at the bottom of the box.

Putting the Printer into the Box

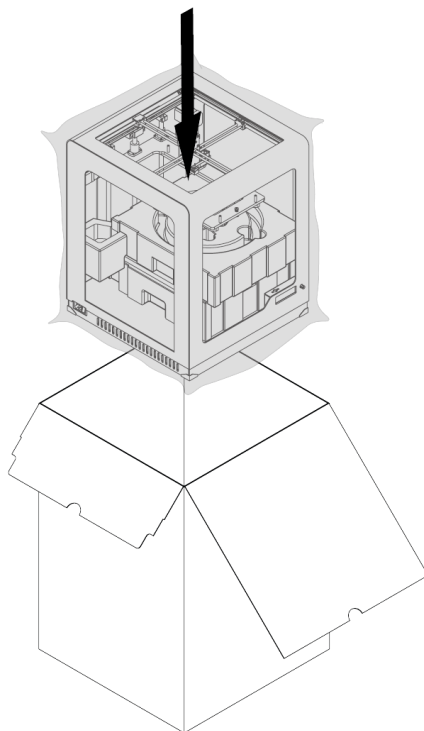

Place the printer on the bottom cushioning inside the box. Bearing in mind the printer's weight (30kg), M300 should be put into the box by two people.

Be careful not to damage the knob next to the display.

Placing the Top Cushioning

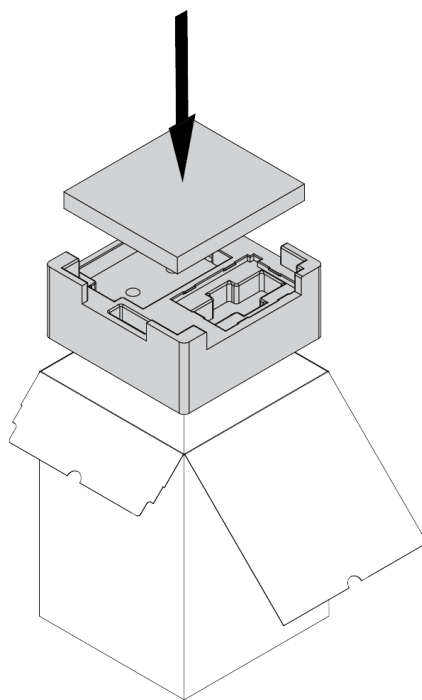

Place the top cushioning on the printer so that the cushioning fits the extruder.

Packing the Printer

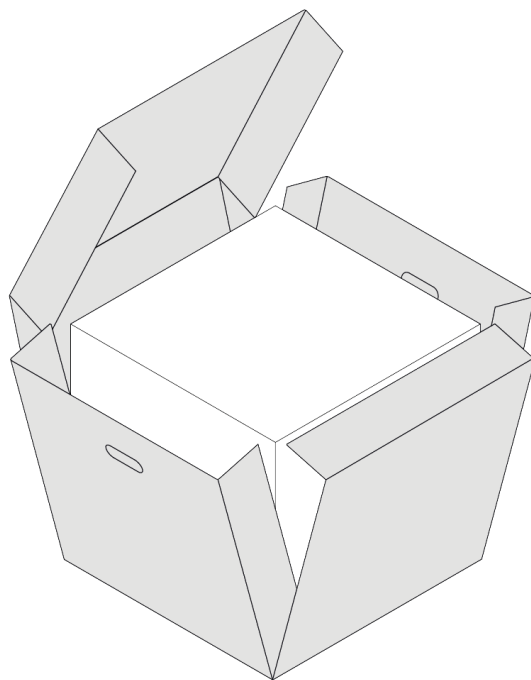

Pack the printer using the provided box.

Taping the Box

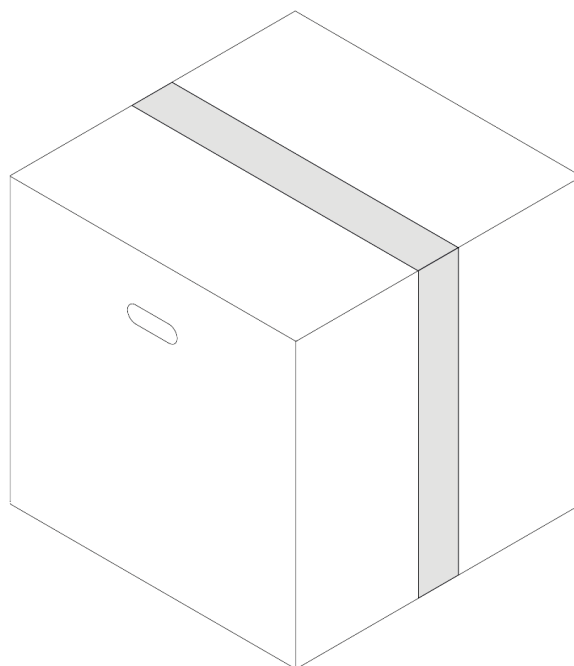

Tape the box.